

hy-gain® 11, 12
by **hy-gain**

MODELS 1291 and 1292
CITIZENS TWO-WAY RADIO
hand-held

Manufactured and Distributed by
Hy-Gain de Puerto Rico, Inc.
P.O. Box 68 State Hwy 31, Km. 4.0
Naguabo, Puerto Rico 00718



First Printing, September, 1976

Original Edition, September, 1976 — PN 820146

Table of Contents

	page
CHAPTER 1—GENERAL INFORMATION	1
Introduction	1
Warranty Service Department	1
How to Ship Returns	1
Purchase of Parts	2
Specifications	2
CHAPTER 2—THEORY OF OPERATION	3
General	3
Transmitter	3
Receiver	3
CHAPTER 3—ALIGNMENT	5
General	5
Recommended Equipment	5
Transmitter Alignment Procedures Models 1291 and 1292	5
Equipment Set-up	5
Transmit Oscillator Alignment	6
RF Output Adjustment	7
Transmitter Frequency Check	7
RF Meter Adjustment	8
Receiver Alignment Procedures Models 1291 and 1292	8
Equipment Set-up	8
RF and IF Stage Adjustments	9
Tight Squelch Adjustment	9
S-Meter Adjustment	9
CHAPTER 4—CHARTS AND DRAWINGS	13
Voltage Measurement Chart	15
Component Outline, Model 1291	17
Component Outline, Model 1292	21
Parts List	25

List of Illustrations

Figure		Page
2-1	Block Diagram, Model 1291	foldout
2-2	Block Diagram, Model 1292	foldout
3-1	Power Line Filter Construction	6
3-2	Equipment Set-up, Transmitter Alignment	6
3-3	Connection of Frequency Counter and Dummy Load	7
3-4	Equipment Set-up, Receiver Alignment	8
3-5	Components Adjusted for Transmitter Alignment	10
3-6	Components Adjusted for Receiver Alignment	11
4-1	Component Outline, Model 1291	19
4-2	Component Outline, Model 1292	23
4-3	Schematic Diagram, Model 1291	foldout
4-4	Schematic Diagram, Model 1292	foldout

CHAPTER 1 — GENERAL INFORMATION

Introduction

This service manual contains all the information needed to service and repair the Hy-Gain 11 and 12 transceivers (Models 1291 and 1291). It includes an explanation of the theory of operation and alignment procedures. Revision, addendum, and errata sheets will be published as needed. Insert them as required in the manual.

The Hy-Gain 11 and 12 are 3 and 6 channel hand-held transceivers respectively; designed and type accepted for Class D Citizens Radio service, as designated by the Federal Communications Commission (FCC).

The transceivers are completely solid state compact units with high reliability and low power consumption. They utilize a unique system of frequency synthesization. One set of channel 11 crystals are installed in the "1" channel position, and additional crystals may be installed in the remaining open sockets.

Warranty Service Department

For help with technical problems, for parts information, and information on local and factory repair facilities, contact the National Service Manager. When you write please include all pertinent information that may be helpful in solving your problem. Address your letter to:

Hy-Gain Warranty Service Department
4900 Superior Street
Lincoln, Nebraska 68504
ATTN: National Service Manager

The Warranty Service Department can repair any unit. Before shipping your unit contact the National Service Manager. Often a problem is field solvable with a little extra help. This can save lost time and shipping costs. Limit factory returns to difficult problems.

How to Ship Returns

To return a unit, get a return authorization first. This is important. You will only delay the handling of the unit if you ship without it. If you must ship immediately, telephone or telex the National Service Manager to have him expedite the matter.

When you request return authorization, you may also request notification of completion of repairs. The notification will include a copy of the bill. Paying the bill before we return your unit can save the cost of a COD fee.

For warranty repair, prepare a letter in duplicate containing the following information (for out-of-warranty repair delete items 2 and 3):

1. your name and address
2. purchaser's name and address
3. proof of purchase
4. serial number
5. complete description of the problem
6. return authorization

Check the unit to see that all parts and screws are in place. Attach an envelope containing a copy of the letter directly to the unit so the information is not overlooked. Wrap the unit and envelope in heavy paper or put them in a plastic bag. If the original carton is not available, place the unit in a strong carton at least *six* inches larger in all three dimensions than the unit. Fill the carton around the unit with resilient packing material (shredded paper, excelsior, bubble pack, etc.). Seal the carton with gummed paper tape, tie with a strong cord and ship by prepaid express, United Parcel Service, or insured parcel post to the address given previously. Mail the original of the letter in a second envelope to the same address.

It is important that the shipment be well packed and fully insured. Damage claims must be settled between you and the carrier and this can delay repair and return of the unit.

All shipments must be sent PREPAID. We *DO NOT ACCEPT* collect shipments. After the unit has been repaired, we will send it back to you COD unless you have prepaid the bill. Unclaimed or refused COD shipments will not be reshipped until payment is received in full. These items become the property of Hy-Gain 60 days after refusal or return and will be sold for payment of charges due.

Units with unauthorized field modifications cannot be accepted for repair.

Purchase of Parts

Parts can be purchased from any Hy-Gain Service Center or from the factory Warranty Service Department. When ordering please supply the following information:

1. unit model number
2. unit serial number
3. part description
4. part number

Specifications

General

Channels (Model 1291) 3 in the Citizens Band (26.965 - 27.255 MHz)
 Channels (Model 1292) 6 in the Citizens Band (26.965 - 27.255 MHz)
 Antenna 11 Section 57 inch telescopic
 Power Requirements 9 VDC - 15 VDC
 Compliance Type accepted under FCC rules, Part 95

Receiver Section

Circuitry Single Conversion superhetrodyne with rf amplifier stage and 455 kHz ceramic filter
 Sensitivity 1.0 uV
 Intermediate frequency 455 kHz
 Selectivity 0.8 watts at 8 ohms

Transmitter Section

RF power output (Model 1291) 1.0 watt
 RF power output (Model 1291) 4.0 watts
 Modulation Class B
 Spurious response rejection All harmonic and spurious suppression better than FCC requirements

CHAPTER 2 — THEORY OF OPERATION

General

The theory of operation for models 1291 and 1292 is divided into two sections, the Receiver and the Transmitter. This material covers the functioning of the transceivers with a minimum of technical involvement. We have not attempted to explain the engineering techniques and approaches that arrived at these circuit designs.

Refer to the block diagrams, Figures 2-1 and 2-2, for visual reference to the theory of operation.

Transmitter

Frequencies for use by the transmitter are generated by a crystal oscillator, Q11. The Transmitter Oscillator generates the frequencies within the 27 MHz band depending on the crystals selected. The signal is then applied to the RF Driver, Q12, and finally to the RF Power Amplifier, Q13.

The transmit signal is modulated as follows. The audio signal from the microphone is amplified by the Mic Amplifier, Q7, and is applied to the AF Amplifier, Q8, where it is again amplified. The signal is coupled across T5 and is applied to the AF Power Amplifier, Q9 and Q10.

From Q9 and Q10, the signal is passed to T6. The secondary of T6 couples the audio signal to the collectors of Q12 and Q13 which modulate the transmitter signal. The modulated signal from the RF Power Amplifier, Q13, is applied to the antenna and radiated.

Switching from receive to transmit is accomplished by a mechanical switch in Model 1291 and 1292. In Model 1292, if the speaker/microphone is used, the Transmit/Receive Switch, Q14 and Q15, provides the same function. This switching network shuts off power to Q11, Q12, and Q13 in the receive mode.

Receiver

In the receive mode signals from the antenna are filtered by the pi-type network and applied to the RF Amplifier, Q1. The amplified RF signal is passed across T2 to the Receiver Mixer, Q2.

Also applied to Q2 is a signal from the Receiver Oscillator, Q5, whose frequency is determined by the channel and crystal selected. The signal is coupled to the base of Q2. The two signals are mixed by Q2 and a difference frequency of 455 kHz is produced. This is the i-f frequency.

The i-f signal passes through the Ceramic Filter, CF, and is applied to the IF Amplifier section consisting of Q3 and Q5. The amplified i-f signal is coupled to the demodulation network by T4.

The demodulation network removes the carrier signal and the remaining audio signal is passed to the AF Pre-Amplifier, Q7, and AF Amplifier, Q8, and the AF Driver, Q9 and Q10. The audio signal is then passed across the audio output transformer, T6, to the speaker.

The squelch functions in the following manner. In the unsquelched condition, Q6, is turned off with 0.0V on its base, allowing Q7 to conduct with a positive potential on its base. In the squelched condition the Squelch Switch, Q6, is saturated, and a low voltage is produced on its collector. This low voltage is also on the base of the Audio Pre-Amplifier, Q7, shutting it off. The squelch level is set by RV2.

CHAPTER 3 — ALIGNMENT

General

These procedures must be followed to align the transceiver. Alignment should not be undertaken unless the technician has adequate test equipment and a full understanding of the circuitry of the transceiver.

IMPORTANT: Tuning adjustment of this transceiver "shall be made by or under the immediate supervision and responsibility of a person holding a first or second-class commercial radio operator license," as stipulated in Part 95.97 (b) of the FCC Rules and Regulations.

The procedures are divided into two main sections, Transmitter Alignment and Receiver Alignment. See *Equipment* below for a complete list of recommended equipment.

These procedures assume that proper voltages are present at all points in the unit, if not, troubleshoot before continuing.

NOTE: The ferrite cores in the tuning coils are easily chipped or broken. Use care when inserting an alignment tool in the coil; insert it straight into the core.

Recommended Equipment

The following equipment is recommended for use in aligning Models 1291 and 1292. All test equipment should be properly calibrated.

Audio Signal Generator, 1 Hz

AC VTVM 1mV measurable

DC Ampere Meter, 2A

Variable Regulated Power Supply, DC 8-15V, 2A or higher

Frequency Counter, 0 to 40 MHz, high input impedance type

VTVM with RF probe

Oscilloscope, 30 MHz, high input impedance

RF Wattmeter and 50 ohm, 5W dummy load

Standard RF Signal Generator, 27 MHz CB band

Speaker Dummy Resistor, 8 ohm, 5W

VOM 20k ohm V

Transmitter Alignment Procedures Models 1291 and 1292

Equipment Set-up

Prior to connecting a unit to test equipment, construct a power line filter as shown in the Figure 3-1.

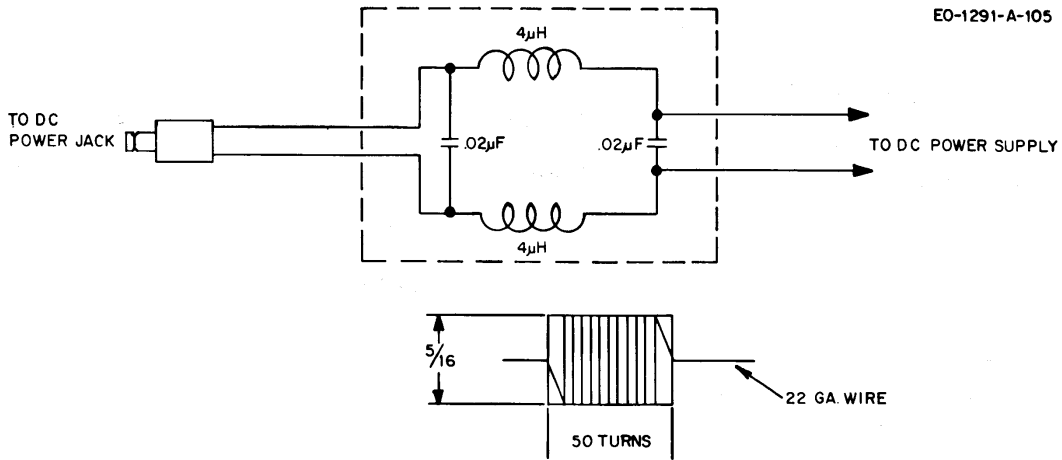

Figure 3-1. Power Line Filter Construction

NOTE: Two coils of 4 μ H each may be used in lieu of winding coils. The coils used must have a current rating of 1 ampere or higher.

1. Using the constructed filter in the power line, connect a DC power supply, set at exactly 12.0 VDC, to the external power jack.
2. Connect the remainder of the test equipment as shown in Figure 3-2.

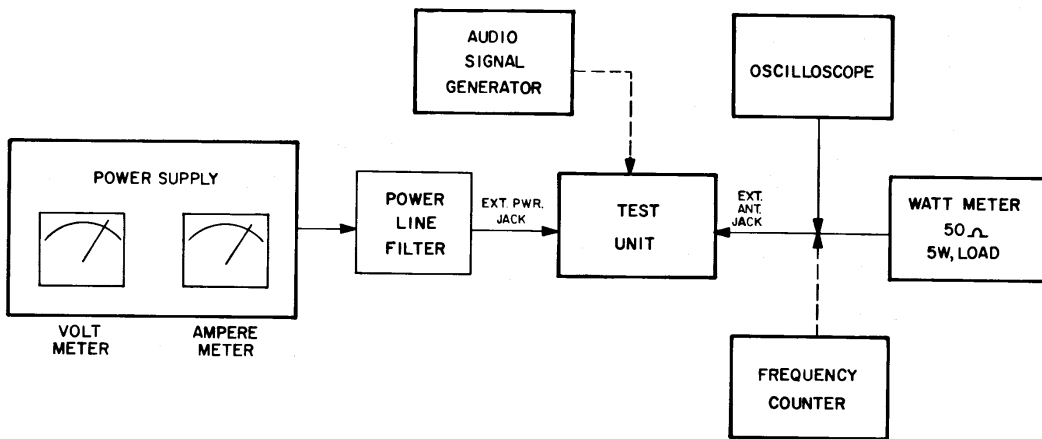

Figure 3-2. Equipment Set-up, Transmitter Alignment

3. Place the channel select switch in the "1" position. (Crystals are assumed to be in "1" crystal sockets.)
4. (Model 1292 only) place the EXT-INT switch in the INT position.

Transmit Oscillator Alignment

1. Key the Transmitter.
2. Turn the core of T7 counterclockwise until oscillation stops.

3. Turn the core of T7 clockwise until oscillation just starts. Turn the T7 core 1½ turns beyond the oscillation starting point.

RF Output Adjustment

1. Key the transmitter.
2. Adjust L1 for maximum RF power output on the wattmeter.
3. Temporarily set the power supply voltage at 9.0 VDC and connect an audio signal of 1 kHz to the test point in the mic circuit as shown on the schematic.
4. Using the oscilloscope, adjust the audio input signal level to obtain about 80% modulation.
5. Adjust L1 for maximum amplitude on the oscilloscope.
6. Remove the audio signal and increase the power supply voltage to 12.0 VDC.
7. A. (Model 1291) Adjust L2 and L4 for an RF output of 1.2 W.
B. (Model 1292) Adjust L2 and L4 for an output of 2.7 watts on the wattmeter.
8. Repeat steps 2 through 7 two or three times.
9. A. (Model 1291) Ensure that the total current drain in the transmit mode is less than 300 mA, using the ammeter on power supply.
B. (Model 1292) Ensure that the total current drain in the transmit mode is less than 650 mA using the ammeter on the power supply.

Transmitter Frequency Check

1. Turn the transceiver off.
2. Connect a dummy load and frequency counter to the antenna jack as shown in Figure 3-3.

E0-0672-A-010

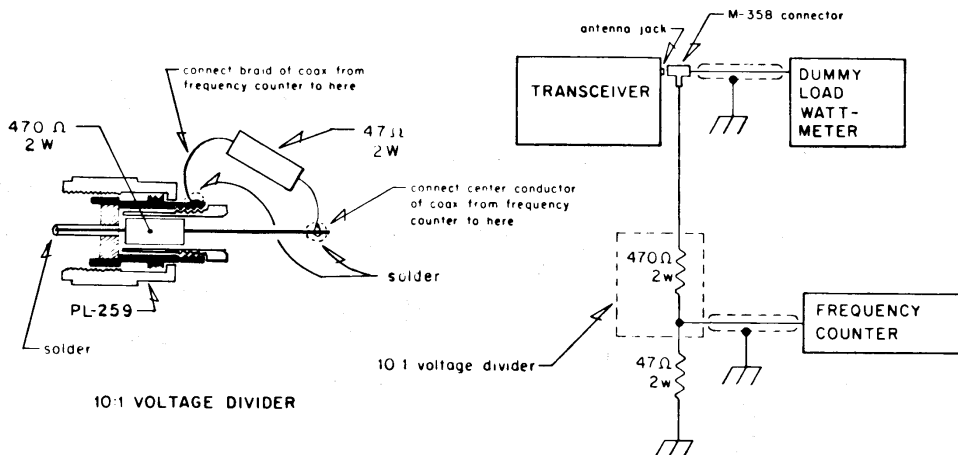

Figure 3-3. Connection of Frequency Counter and Dummy Load

3. Key the transmitter.

4. Check the frequency of each channel crystal installed with the chart below. Frequencies should be within ± 800 Hz at 25°C.

CHANNEL FREQUENCY

Channel	MHz	Channel	MHz
1	26.965	13	27.115
2	26.975	14	27.125
3	26.985	15	27.135
4	27.005	16	27.155
5	27.015	17	27.165
6	27.025	18	27.175
7	27.035	19	27.185
8	27.055	20	27.205
9	27.065	21	27.215
10	27.075	22	27.225
11	27.085	23	27.255
12	27.105		

RF Meter Adjustment

1. Key the transmitter.

2. Adjust L3 so that the meter indicates 80% of full scale deflection on the blue scale.

Receiver Alignment Equipment Set-up Procedures Models 1291 and 1292

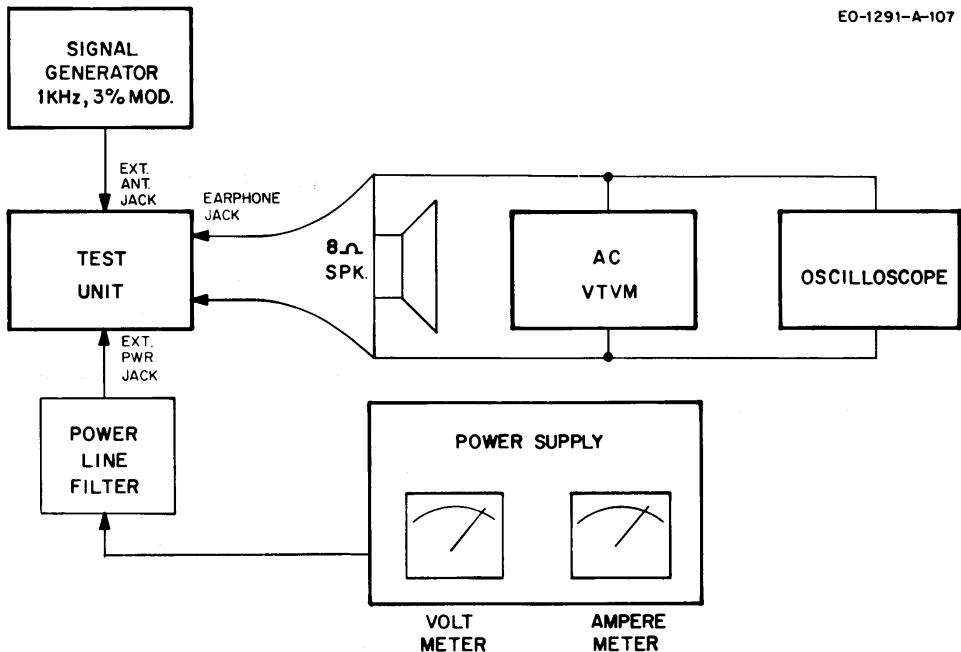

Figure 3-4. Equipment Set-up, Receiver Alignment

1. Using the constructed power line filter, connect the power supply, set at 12.0 VDC, to the test unit.
2. Connect the remainder of the test equipment as shown in Figure 3-4.
3. Place the channel selector in the "1" position.
4. Place the squelch control in the OFF position.
5. Set the volume control in the mid-range position.

RF and IF Stage Adjustments

1. Adjust the signal generator to obtain 1.0V audio output across the speaker terminals.
2. Adjust T2 through T4 two or three times for maximum audio output.
3. Decrease the signal generator output to 1 μ V and adjust T1 through T4 for maximum output.

Tight Squelch Adjustment

1. Set the signal generator to provide a 100 μ V output.
2. Adjust the volume control to obtain a 0.63V audio output on the AC VTVM.
3. Set the squelch control to the maximum position.
4. Adjust RV2 until the audio output voltage decreases to at least .063 mV (or the receiver is squelched).

S-Meter Adjustment

1. Adjust the signal generator output to provide a 5 μ V input signal.
2. Adjust RV1 so the meter indicates 80% on the red scale.

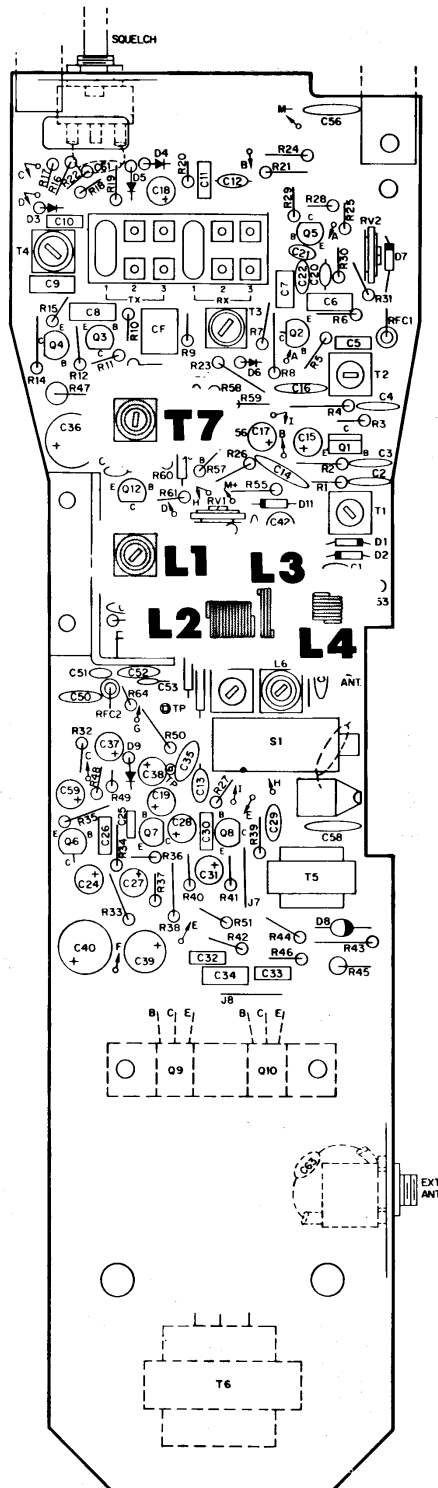

Figure 3-5. Components Adjusted for Transmitter Alignment

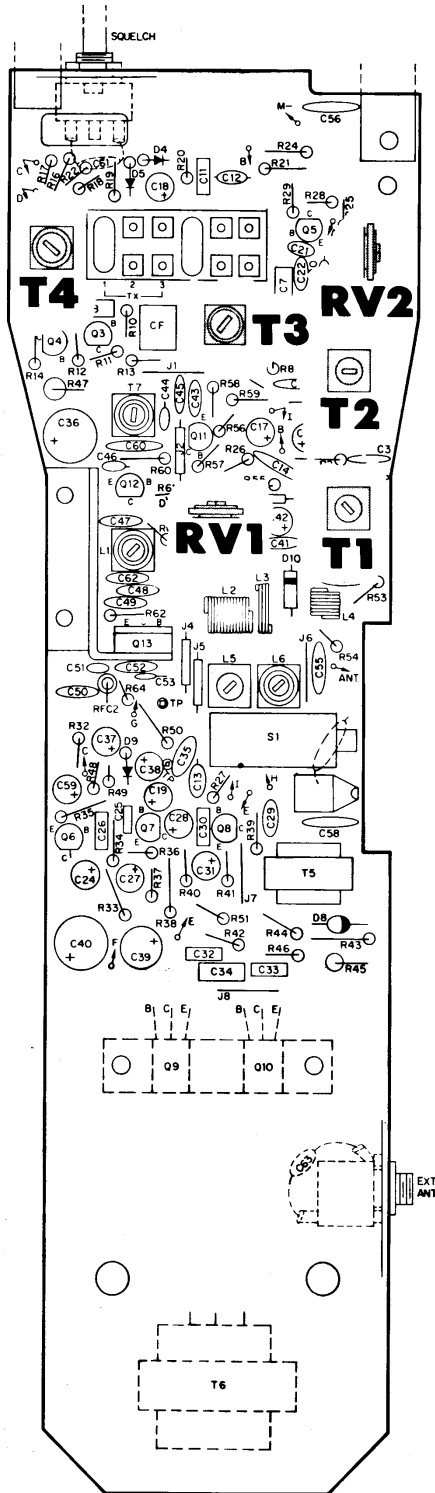

Figure 3-6. Components Adjusted for Receiver Alignment

Voltage Measurement Chart

Model 1291

Reference Designator	Mode	E	B	C
Q1	RX	.83V	1.53V	10.21V
Q2	RX	.85V	1.50V	9.65V
Q3	RX	0V	.70V	1.94V
Q4	RX	1.23V	1.94V	8.98V
Q5	RX	1.89V	2.31V	6.43V
Q6	RX	0V	.03V	6.79V
Q7	RX	2.72V	3.35V	6.44V
Q8	RX	1.50V	2.14V	9.68V
Q9	RX	.04V	.67V	11.88V
Q10	RX	.04V	.67V	11.82V
Q11	TX	1.39V	1.04V	11.24V
Q12	TX	0V	-.6V	10.43V
Q13	TX	0V	-.2V	11.27V

Model 1292

Reference Designator	Mode	E	B	C
Q1	RX	.56V	1.22V	6.32V
Q2	RX	.54V	1.20V	5.97V
Q3	RX	0V	.67V	1.73V
Q4	RX	1.03V	1.74V	5.82V
Q5	RX	1.23V	1.90V	5.11V
Q6	RX	0V	.02V	6.49V
Q7	RX	2.58V	3.23V	6.05V
Q8	RX	1.77V	2.40V	9.92V
Q9	RX	.02V	.64V	11.96V
Q10	RX	.02V	.64V	11.95V
Q11	TX	1.00V	1.70V	10.72V
Q12	TX	0V	.06V	8.5V
Q13	TX	0V	.06V	9.9V
Q14	RX	6.80V	7.22V	11.99V
	TX	2.78V	.86V	11.99V
Q15	RX	11.99V	11.42V	.02V
	TX	11.89V	11.15V	

NOTE: All voltage measurements are taken with the power supply set at exactly 12.0VDC.

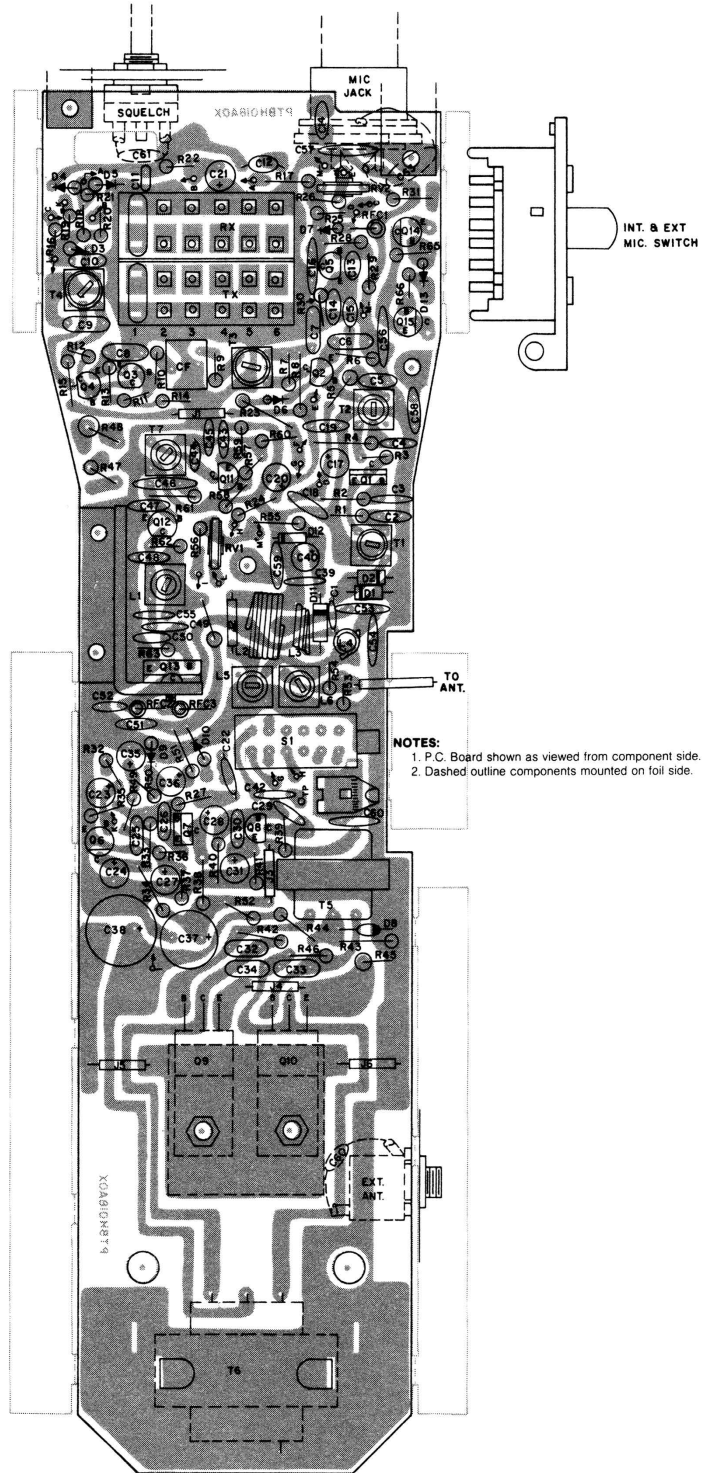

Figure 4-2. Component Outline, Model 1292

Main P.C. Board

□ - 1291 only

■ - 1292 only

Unmarked components are common to both radios.

Reference Designator	Description	Part No.
	□ main p.c. board, complete	AP-TBH019AA
	□ main p.c. board, plated and drilled	PT-BH019AOX
	■ main p.c. board, complete	AP-TBH018AA
	■ main p.c. board, plated and drilled	PT-BH018AOX
C1	27pF, 50V, ceramic disc	CC-DB270JOK
C2	.022uF, 25V, ceramic disc	CK-DA223ZFK
C3	.022uF, 25V, ceramic disc	CK-DA223ZFK
C4	.022uF, 25V, ceramic disc	CK-DA223ZFK
C5	.022uF, 50V, mylar	CQ-MB223KEH
C6	.047uF, 50V, mylar	CQ-MB473KEH
C7	.047uF, 50V, mylar	CQ-MB473KEH
C8	.047uF, 50V, mylar	CQ-MB473KEH
C9	.047uF, 50V, mylar	CQ-MB473KEH
C10	.022uF, 50V, mylar	CQ-MB223KEH
C11	.022uF, 50V, mylar	CQ-MB223KEH
C12	.05uF, 12V, ceramic disc	CB-D1B503MM
C13	22pF, 50V, ceramic disc	CC-DB220KOK
C14	□ 47uF, 50V, ceramic disc	CK-DA473ZFK
	■ 82pF, 50V, ceramic disc	CC-DB820KOK
C15	□ 10uF, 16V, electrolytic	CE-AD100ALN
	■ 10pF, 50V, ceramic disc	CC-DB100DOK
C16	.047uF, 25V, ceramic disc	CK-DA473ZFK
C17	10uF, 16V, electrolytic	CE-AD100ALN
C18	□ 33uF, 10V, electrolytic	CE-AC330ALN
	■ .047uF, 25V, ceramic disc	CK-DA473ZFK
C19	□ .47uF, 50V, electrolytic	CE-AGR47ALN
	■ .047uF, 25V, ceramic disc	CK-DA473ZFK
C20	□ 10pF, 50V, ceramic disc	CC-DB100DOK
	■ 10uF, 16V, electrolytic	CE-AD100ALN
C21	□ 22pF, 50V, ceramic disc	CC-DB220JOK
	■ 33uF, 10V, electrolytic	CE-AC330ALN
C22	□ 82pF, 50V, ceramic disc	CC-DB820JOK
	■ .05uF, 12V, ceramic disc	CB-D1B503MM
C23	□ (not used)	
	■ 10uF, 16V, electrolytic	CE-AD100ALN
C24	33uF, 10V, electrolytic	CE-AC330ALN
C25	□ .0047, 50V, mylar	CQ-MB472KEH
	■ .022uF, 50V, mylar	CQ-MB223KEH
C26	□ .022uF, 50V, mylar	CQ-MB223KEH
	■ .0047uF, 50V, mylar	CQ-MB472KEH
C27	10uF, 16V, electrolytic	CE-AD100ALN
C28	□ 1uF, 50V, electrolytic	CE-AG010ALN
	■ .47uF, 50V, electrolytic	CE-AGR47ALN
C29	50pF, 50V, ceramic disc	CC-DB500JOK
C30	□ .02uF, 50V, mylar	CQ-MB223KEH
	■ .0047uF, 50V, mylar	CQ-MB472KEH
C31	10uF, 16V, electrolytic	CE-AD100ALN
C32	□ .01uF, 50V, mylar	CQ-MB223KEH
	■ .022uF, 50V, mylar	CQ-MB223KEH
C33	□ .01uF, 50V, mylar	CQ-MB103JOK
	■ .022uF, 50V, mylar	CQ-MB223KEH
C34	.047uF, 50V, mylar	CQ-MB473KEH
C35	□ .1uF, 12V, ceramic disc	CB-D1B104MM
	■ 33uF, 10V, electrolytic	CE-AC330ALN
C36	□ 100uF, 16V, electrolytic	CE-AD101ALN

Reference Designator	Description	Part No.
C37	■ 1uF, 50V, ceramic disc	CE-AG010ALN
	□ 33uF, 10V, electrolytic	CE-AC330ALN
C38	■ 100uF, 16V, electrolytic	CE-AD101ALN
	□ 47uF, 50V, electrolytic	CE-AGR47ALN
C39	■ 470uF, 16V, electrolytic	CE-AD471AUN
	□ 47uF, 16V, electrolytic	CE-AD470ALN
C40	■ .01uF, 25V, ceramic disc	CK-DA103ZFK
	□ 100uF, 16V, electrolytic	CE-AD101ALN
C41	■ 10uF, 16V, electrolytic	CE-AD100ALN
	□ .01uF, 25V, ceramic disc	CK-DA103ZFK
C42	■ .05uF, 12V, ceramic disc	CB-D1B503MM
	□ 10uF, 16V, electrolytic	CE-AD100ALN
C43	■ .1uF, 12V, ceramic disc	CB-D1B104MM
	□ 150pF, 50V, ceramic disc	CC-DB151JOK
C44	■ 120pF, 50V, ceramic disc	CC-DB121JOK
	□ 39pF, 50V, ceramic disc	CC-DB390JOK
C45	□ .02uF, 25V, ceramic disc	CK-DA223ZFK
	■ .0022uF, 25V, ceramic disc	CK-DA223ZFK
C46	□ 30pF, 50V, ceramic disc	CC-DB300JOK
	■ 470pF, 50V, ceramic disc	CC-DB471JOK
C47	□ .022uF, 25V, ceramic disc	CK-DA223ZFK
	■ 50pF, 50V, ceramic disc	CC-DB500JOK
C48	□ 270pF, 50V, ceramic disc	CC-DB271JOK
	■ .022uF, 25V, ceramic disc	CK-DA223ZFK
C49	□ 220pF, 50V, ceramic disc	CC-DB221JOK
	■ 390pF, 50V, ceramic disc	CC-DB391JOK
C50	□ .022uF, 25V, ceramic disc	CK-DA223ZFK
	■ 150pF, 50V, ceramic disc	CC-DB151JOK
C51	□ 10pF, 50V, ceramic disc	CC-DB100DOK
	■ .022uF, 50V, ceramic disc	CK-DA223ZFK
C52	□ 82pF, 50V, ceramic disc	CC-DB820JOK
	■ 56pF, 50V, ceramic disc	CC-DB560JOK
C53	□ 33pF, 50V, ceramic disc	CC-DB330JOK
	■ 470pF, 50V, ceramic disc	CC-DB471JOK
C54	□ 270pF, 50V, ceramic disc	CC-DB271JOK
	■ 440pF, 50V, ceramic disc	CC-DB441JOK
C55	□ 330pF, 50V, ceramic disc	CC-DB331JOK
	■ .022uF, 25V, ceramic disc	CK-DA223ZFK
C56	.047uF, 25V, ceramic disc	CK-DA473ZFK
C57	.047uF, 25V, ceramic disc	CK-DA473ZFK
C58	.047uF, 25V, ceramic disc	CK-DA473ZFK
C59	□ 10uF, 16V, electrolytic	CE-AD100ALN
	■ .047uF, 25V, ceramic disc	CK-DA473ZFK
C60	□ 330pF, 50V, ceramic disc	CC-DB331JOK
	■ .047uF, 25V, ceramic disc	CK-DA473ZFK
CF	ceramic filter	FB-R455A08M
D1	1S1555, silicon	QD-SS1555XT
D2	1S1555, silicon	QD-SS1555XT
D3	1N60, germanium	QD-G1N60XXT
D4	OA-95	QD-G0A95XXT
D5	1N60, germanium	QD-G1N60XXT
D6	1S1555, silicon	QD-SS1555XT
D7	RD6.8E (BZ), zener	QD-ZRD6EB2A
D8	□ MA-26, varistor	QV-AMA26XXN
	■ VD1123, varistor	QV-BD11230A
D9	1N60, germanium	QD-G1N60XXT
D10	□ 1N60, germanium	QD-G1N60XXT
	■ V06C, silicon	QD-SV06CXHX
D11	□ 1S1555, silicon	QD-SS1555XT
	■ 1N60, germanium	QD-G1N60XXT
D12	□ (not used)	
	■ 1S1555, silicon	QD-SS1555XT
D13	□ (not used)	
	■ 1S1555, silicon	QD-SS1555XT

Reference Designator	Description	Part No.
L1	<input type="checkbox"/> rf coil	TR-07CR005S
	<input checked="" type="checkbox"/> rf coil	TR-07CR003S
L2	<input type="checkbox"/> rf coil	LA-1JE1011A
	<input checked="" type="checkbox"/> rf coil	LA-1UH0705A
L3	<input type="checkbox"/> rf coil	LA-1NE0703A
	<input checked="" type="checkbox"/> rf coil	LA-3JD1006A
L4	<input type="checkbox"/> rf coil	LA-1JE2007A
	<input checked="" type="checkbox"/> rf coil	LA-1NE0703A
L5	<input type="checkbox"/> rf coil	TR-07NM001T
	<input checked="" type="checkbox"/> rf coil	TR-07NM001T
L6	<input type="checkbox"/> rf coil	TR-07CR004S
	<input checked="" type="checkbox"/> rf coil	TR-07CR004S
Q1	2SC460(A)	QT-C0460XAB
Q2	2SC839(H)	QT-C0839XBA
Q3	2SC839(H)	QT-C0839XBA
Q4	2SC839(H)	QT-C0839XBA
Q5	2SC839(H)	QT-C0839XBA
Q6	2SC945(R)	QT-C0945XAA
Q7	<input type="checkbox"/> 2SC945(R)	QT-C0945XAA
	<input checked="" type="checkbox"/> 2SC458LG(C)	AT-C0458LBB
Q8	2SC945(P)	QT-C0945XDA
Q9	<input type="checkbox"/> 2SC1383(Q)	QT-C1383XAN
	<input checked="" type="checkbox"/> 2SD325(E)	QT-D0325XAC
Q10	<input type="checkbox"/> 2SC1383(Q)	QT-C1383XAN
	<input checked="" type="checkbox"/> 2SD325(E)	QT-D0325XAC
Q11	<input type="checkbox"/> 2SC945(R)	QT-C0945XAA
	<input checked="" type="checkbox"/> 2SC1306-1	QT-C1306XZA
Q12	<input type="checkbox"/> 2SC815(L)	QT-C0815XCA
	<input checked="" type="checkbox"/> 2SC1475(3)	QT-C1475XBS
Q13	<input type="checkbox"/> 2SC1760-3	QT-C1760XAS
	<input checked="" type="checkbox"/> 2SC1306-1	QT-C1306XZA
Q14	<input type="checkbox"/> (not used)	
	<input checked="" type="checkbox"/> 2SA562(Y)	QT-A0562XAT
Q15	<input type="checkbox"/> (not used)	
	<input checked="" type="checkbox"/> 2SC735(Y)	QT-C0735XCT
R1	1.8k, 10%, 1/4w, carbon film	RD-14WJ182N
R2	680, 10%, 1/4w, carbon film	RD-14WJ681N
R3	220, 10%, 1/4w, carbon film	RD-14WJ221N
R4	470, 10%, 1/4w, carbon film	RD-14WJ471N
R5	1.8k, 10%, 1/4w, carbon film	RD-14WJ182N
R6	470, 10%, 1/4w, carbon film	RD-14WJ471N
R7	<input type="checkbox"/> 33k, 10%, 1/4w, carbon film	RD-14WJ333N
	<input checked="" type="checkbox"/> 68k, 10%, 1/4w, carbon film	RD-14WJ683N
R8	470, 10%, 1/4w, carbon film	RD-14WJ471N
R9	1.5k, 10%, 1/4w, carbon film	RD-14WJ152N
R10	390, 10%, 1/4w, carbon film	RD-14WJ391N
R11	22k, 10%, 1/4w, carbon film	RD-14WJ223N
R12	<input type="checkbox"/> 120, 10%, 1/4w, carbon film	RD-14WJ121N
	<input checked="" type="checkbox"/> 4.7k, 10%, 1/4w, carbon film	RD-14WJ472N
R13	<input type="checkbox"/> 470, 10%, 1/4w, carbon film	RD-14WJ471N
	<input checked="" type="checkbox"/> 120, 10%, 1/4w, carbon film	RD-14WJ121N
R14	<input type="checkbox"/> 4.7k, 10%, 1/4w, carbon film	RD-14WJ472N
	<input checked="" type="checkbox"/> 470, 10%, 1/4w, carbon film	RD-14WJ471N
R15	470, 10%, 1/4w, carbon film	RD-14WJ471N
R16	5.6k, 10%, 1/4w, carbon film	RD-14WJ562N
R17	<input type="checkbox"/> 10k, 10%, 1/4w, carbon film	RD-14WJ103N
	<input checked="" type="checkbox"/> 100k, 10%, 1/4w, carbon film	RD-14WJ104N
R18	<input type="checkbox"/> 3.9k, 10%, 1/4w, carbon film	RD-14WJ392N
	<input checked="" type="checkbox"/> 2.2k, 10%, 1/4w, carbon film	RD-14WJ223N
R19	<input type="checkbox"/> 1.8k, 10%, 1/4w, carbon film	RD-14WJ182N
	<input checked="" type="checkbox"/> 10k, 10%, 1/4w, carbon film	RD-14WJ103N
R20	<input type="checkbox"/> 10k, 10%, 1/4w, carbon film	RD-14WJ103N
	<input checked="" type="checkbox"/> 3.9k, 10%, 1/4w, carbon film	RD-14WJ392N

Reference Designator	Description	Part No.
R21	□ 100k, 10%, 1/4w, carbon film	RD-14WJ104N
	■ 1.8k, 10%, 1/4w, carbon film	RD-14WJ82N
R22	□ 2.2k, 10%, 1/4w, carbon film	RD-14WJ222N
	■ 10k, 10%, 1/4w, carbon film	RD-14WJ103N
R23	1.8k, 10%, 1/4w, carbon film	RD-14WJ182N
R24	□ 18k, 10%, 1/4w, carbon film	RD-14WJ183N
	■ 100, 10%, 1/4w, carbon film	RD-14WJ101N
R25	□ 470, 10%, 1/4w, carbon film	RD-14WJ471N
	■ 18k, 10%, 1/4w, carbon film	RD-14WJ183N
R26	□ 100, 10%, 1/4w, carbon film	RD-14WJ101N
	■ 470, 10%, 1/4w, carbon film	RD-14WJ471N
R27	□ 1k, 10%, 1/4w, carbon film	RD-14WJ102N
	■ 27k, 10%, 1/4w, carbon film	RD-14WJ273N
R28	4.7k, 10%, 1/4w, carbon film	RD-14WJ272N
R29	2.7k, 10%, 1/4w, carbon film	RD-14WJ272N
R30	680, 10%, 1/4w, carbon film	RD-14WJ681N
R31	10k, 10%, 1/4w, carbon film	RD-14WJ103N
R32	2.2k, 10%, 1/4w, carbon film	RD-14WJ222N
R33	□ 5.6k, 10%, 1/4w, carbon film	RD-14WJ562N
	■ 4.7k, 10%, 1/4w, carbon film	RD-14WJ472N
R34	4.7k, 10%, 1/4w, carbon film	RD-14WJ472N
	5.6k, 10%, 1/4w, carbon film	RD-14WJ562N
R35	4.7k, 10%, 1/4w, carbon film	RD-14WJ472N
R36	□ 220, 10%, 1/4w, carbon film	RD-14WJ221N
	■ 100, 10%, 1/4w, carbon film	RD-14WJ101N
R37	2.7k, 10%, 1/4w, carbon film	RD-14WJ272NI
R38	4.7k, 10%, 1/4w, carbon film	RD-14WJ472N
R39	22k, 10%, 1/4w, carbon film	RD-14WJ223N
R40	□ 5.6k, 10%, 1/4w, carbon film	RD-14WJ562N
	■ 6.8k, 10%, 1/4w, carbon film	RD-14WJ682N
R41	□ 470, 10%, 1/4w, carbon film	RD-14WJ471N
	■ 330, 10%, 1/4w, carbon film	RD-14WJ331N
R42	15k, 10%, 1/4w, carbon film	RD-14WJ153N
R43	□ 270, 10%, 1/4w, carbon film	RD-14WJ271N
	■ 150, 10%, 1/4w, carbon film	RD-14WJ151N
R44	□ 2.7, 10%, 1/4w, carbon film	RD-14WJ272N
	■ 2.2k, 10%, 1/4w, carbon film	RD-14WJ222N
R45	.82, 10%, 1w, metal oxide	RX-1ANJR82N
R46	15k, 10%, 1/4w, carbon film	RD-14WJ153N
R47	□ 2.7, 10%, 1w, metal oxide	RX-1ANJ2R7N
	■ 10, 10%, 1w, metal oxide	RX-1ANJ100N
R48	□ 2.2k, 10%, 1/4w, carbon film	RD-14WJ222N
	■ 8.2, 10%, 1w, metal oxide	RX-2ANJ8R2N
R49	□ 2.2, 10%, 1/4w, carbon film	RD-14WJ222N
	■ 1.5k, 10%, 1/4w, carbon film	RD-14WJ152N
R50	□ 270, 10%, 1/4w, carbon film	RD-14WJ271N
	■ 2.2k, 10%, 1/4w, carbon film	RD-14WJ222N
R51	□ 220, 10%, 1/4w, carbon film	RD-14WJ221N
	■ 180, 10%, 1/4w, carbon film	RD-14WJ181N
R52	□ 82k, 10%, 1/4w, carbon film	RD-14WJ823N
	■ 220, 10%, 1/4w, carbon film	RD-14WJ221N
R53	4.7k, 10%, 1/4w, carbon film	RD-14WJ472N
R54	1k, 10%, 1/4w, carbon film	RD-14WJ102N
R55	2.2k, 10%, 1/4w, carbon film	RD-14WJ222N
R56	□ 12k, 10%, 1/4w, carbon film	RD-14WJ123N
	■ 82k, 10%, 1/4w, carbon film	RD-14WJ823N
R57	□ 1.8k, 10%, 1/4w, carbon film	RD-14WJ182N
	■ 12k, 10%, 1/4w, carbon film	RD-14WJ123N
R58	□ 120, 10%, 1/4w, carbon film	RD-14WJ121N
	■ 2.2k, 10%, 1/4w, carbon film	RD-14WJ222N
R59	100, 10%, 1/4w, carbon film	RD-14WJ101N
R60	□ 680, 10%, 1/4w, carbon film	RD-14WJ681N
	■ 100, 10%, 1/4w, carbon film	RD-14WJ101N
R61	□ 680, 10%, 1/4w, carbon film	RD-14WJ681N
	■ 47, 10%, 1/4w, carbon film	RD-14WJ470N

Reference Designator	Description	Part No.
R62	<input type="checkbox"/> 150, 10%, ¼w, carbon film	RD-14WJ151N
	<input checked="" type="checkbox"/> 220, 10%, ¼w, carbon film	RD-14WJ221N
R63	33, 10%, ¼w, carbon film	RD-14WJ330N
R64	<input type="checkbox"/> 1.5k, 10%, ¼w, carbon film	RD-14WJ152N
	<input checked="" type="checkbox"/> 15, 10%, 1w, metal oxide	RX-1ANJ150N
R65	<input type="checkbox"/> (not used)	
	<input checked="" type="checkbox"/> 680, 10%, ¼w, carbon film	RD-14WJ681N
R66	<input type="checkbox"/> (not used)	
	<input checked="" type="checkbox"/> 3.3k, 10%, ¼w, carbon film	RD-14WJ332N
RFC1	rf coil	LD-ADA3038A
RFC2	rf coil	LD-ADA3038A
RFC3	<input type="checkbox"/> (not used)	
	<input checked="" type="checkbox"/> rf coil	LD-ADX3825M
RV1	10k, potentiometer	RP-DNB10304
RV2	20k, potentiometer	RP-DNB20302
S1	switch, push	SP-01ABA03L
T1	rf coil	TR-07MP005T
T2	rf coil	TR-07CM003T
T3	i-f transformer	TR-07LA012T
T4	i-f transformer	TR-07LA017T
T5	af transformer	TA-Y19A001W
T6	<input type="checkbox"/> af transformer	TB-G24A001W
	<input checked="" type="checkbox"/> af transformer	TB-G24A001W
T7	rf transformer	TR-07CP003S

Chassis Mounted Components

Reference Designator	Description	Part No.
C61	.022uF, 500V, ceramic disc	CK-DA223ZFK
C62	<input type="checkbox"/> (not used)	
	<input checked="" type="checkbox"/> 220pF, 50V, ceramic disc	CC-DB221JOK
J1	jack, antenna	YJ-T03S003Z
J2	jack, speaker	YJ-R03S002Z
J3	jack, power/change	YJ-B03S002Z
J4	<input type="checkbox"/> (not used)	
	<input checked="" type="checkbox"/> jack, mic, 4-pin	YJ-Z04S002Z
M	meter	ZM-J2017M02
mic	microphone	ZG-AZZ20101
S2	<input type="checkbox"/> switch, rotary	SR-0403104H
	<input checked="" type="checkbox"/> switch, slide	SS-040202ZL
S3	<input type="checkbox"/> (not used)	
	<input checked="" type="checkbox"/> switch, rotary	SR-0Z06106H
SP	speaker	ZQ-A0570802
VR3	50k, potentiometer (volume)	RV-NB503A03
VR4	10k, potentiometer (squelch)	RV-NA103C02
X1	26.630 MHz crystal	XC-R3A5011T
X2	27.085 MHz crystal	XC-T3A5011T

Mechanical Parts

Part No.	Description	Qty.
ME-65PAX003	<input type="checkbox"/> panel, front	1
ME-65PAX002	<input checked="" type="checkbox"/> panel, front	1
VB-866SM001	frame, main	1
VB-865SB003	cover, rear	1
VB-663SB001	cover, battery	1
VS-551SB001	cover, crystal	1
VM-171RB001	bushing, squelch knob	2
VM-171RB002	bushing, channel knob	1
VM-276SC002	knob, squelch	2
VM-276SC001	knob, channel	1
MK-144ZC001	knob, push button	1
	<input type="checkbox"/> (not used)	
MS-556SZ001	<input checked="" type="checkbox"/> bracket, potentiometer mounting	1
ML-211SZ007	bracket, p.c. board mounting	1
	bracket, mic holding	1
MS-516SZ001	bracket, push button	1
ML-222SZ009	bracket, speaker mounting	2
MW-261SD001	spring, push button	2
	<input type="checkbox"/> (not used)	
VM-170RX001	<input checked="" type="checkbox"/> cap, mic jack	1

Accessory Parts

Part No.	Description	Qty.
	belt	1
MT-264BC005	screw, belt	2

